

NOTES:

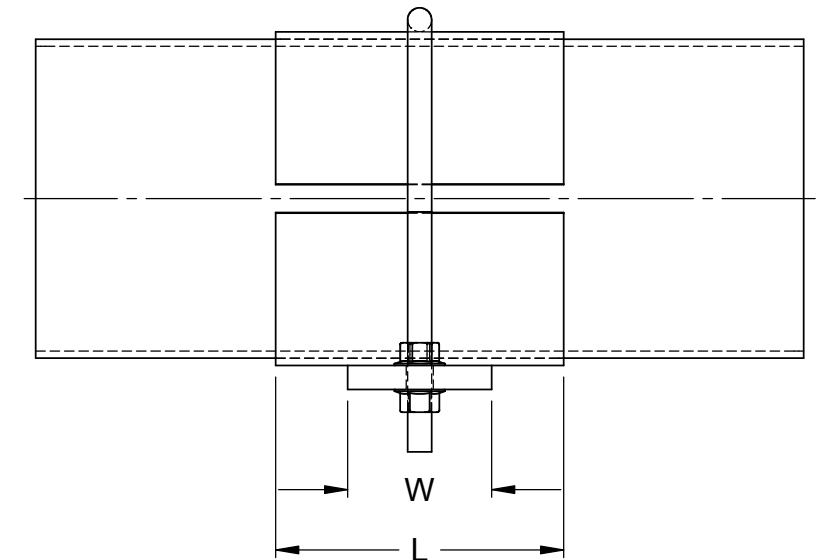

1/16" to 1/8" clearance recommended on each side and top

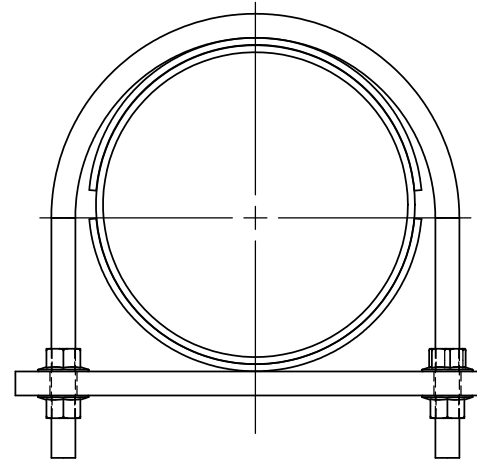
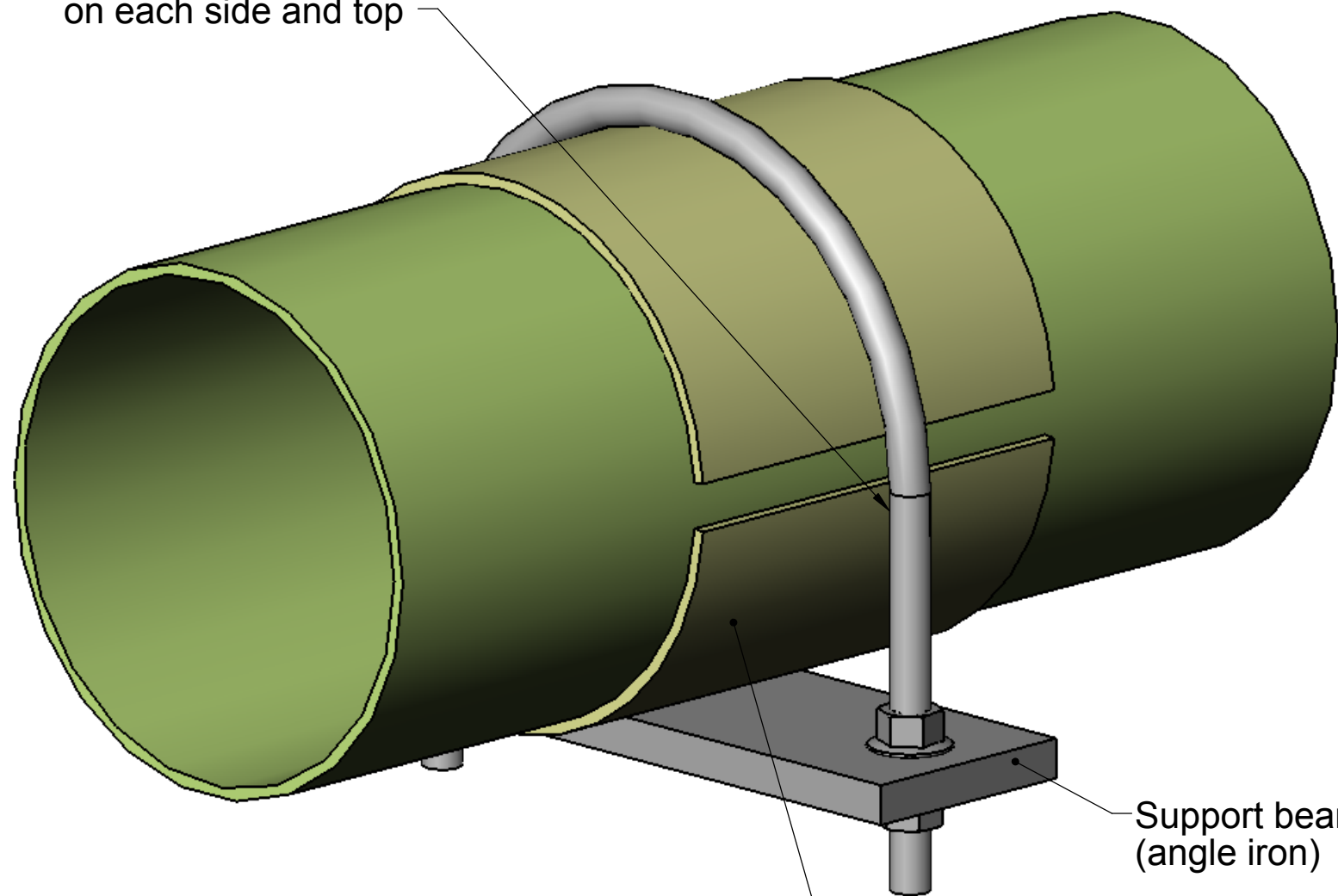

Pipe Support Saddle Length (L) – Minimum Steel Width (W)

Use when circumferential contact less than 180°, or support steel width less than indicated minimum

Pipe Size (in)	CL-2030, RB-2530, Chem Thread, Z-Core		Red Thread II, Green Thread, Silver Streak, F-Chem, CL-1520, RB-1520	
	Min Steel Width (in)	Contact Angle 110 – 120°	Min Steel Width (in)	Contact Angle 170 - 180°
1"	7/8	3	7/8	2
1 1/2"	7/8	3	7/8	2
2"	7/8	4	7/8	4
3"	1-1/4	4	1-1/4	4
4"	1-1/4	4	1-1/4	4
6"	1-1/2	4	1-1/2	6
8"	1-3/4	5-5/8"	1-7/8	8
10"	1-3/4	8-3/8"	2-5/8	10
12"	2	8-3/8"	3-1/4	12
14"	2	8-3/8"	4	12
16"	-	-	4	12
18"	-	-	4	12
20"	-	-	4	12
24"	-	-	4	12

*Support saddles should be bonded in position.

*A thin layer of elastomer could also be placed between the U-Bolt and the pipe

Eastern Canada #1 - 125 Main Street Woodstock, Ontario N4S 1T1
 Western Canada #100, 18012 - 105 Avenue Edmonton, Alberta T5S 2P1
 Toll Free: (800) 410-4802
 Fax: (519) 537-8321
 frp@frpsolutions.com

Fibreglass Solutions Inc.

U Bolt Guide

FRP-G-1

THIRD ANGLE PROJECTION

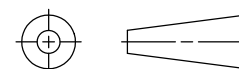

CUSTOMER: X
 PROJECT: Anchor, Support and Guide Design
 DRAWN BY: J.GANDER
 CHECKED BY: B.GOWLAND
 APPROVED BY: B.GOWLAND

DATE: 30 Jan 06
 DATE: 28 Feb 06
 DATE: 18 Apr 06

SIZE: -
 SCALE: Not to Scale

WEIGHT: N/A lbs

SHEET 1 OF 1